

## SOT-23 Plastic-Encapsulate Diodes

### CMSD2004S SWITCHING DIODE

#### FEATURES

CMSD2004S type is a silicon switching dual in series diode manufactured by the epitaxial planar process, designed for applications requiring high voltage capability. Power dissipation

MARKING : B6D



Solid dot = Green molding compound device,  
if none, the normal device

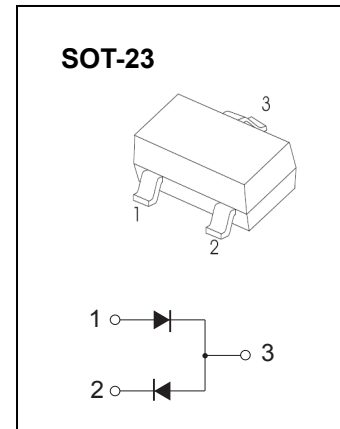

#### Maximum Ratings @Ta=25°C

Parameter	Symbol	Limit	Unit
Non-Repetitive Peak Reverse Voltage	$V_{RM}$	300	V
DC Blocking Voltage	$V_R$	240	V
5 j YfU YF YWZYX Ci ldi hCurrent	$I_o$	200	mA
Continuous Forward Current	$I_F$	225	mA
Peak Repetitive Forward Current	$I_{FRM}$	625	mA
Non-Repetitive Peak Forward Surge Current @t=8.3ms	$I_{FSM}$	2.5	A
Power Dissipation	$P_D$	250	mW
Thermal Resistance From Junction to Ambient	$R_{\theta JA}$	500	°C/W
Junction Temperature	$T_J$	150	°C
Storage Temperature Range	$T_{STG}$	-55~+150	°C

#### ELECTRICAL CHARACTERISTICS (Ta=25°C unless otherwise specified)

Parameter	Symbol	Test conditions	Min	Max	Unit
Reverse breakdown voltage	$V_{(BR)}$	$I_R = 100\mu A$	240		V
Reverse voltage leakage current	$I_R$	$V_R = 240V$		0.1	$\mu A$
Forward voltage	$V_F$	$I_F = 100mA$		1	V
Diode capacitance	$C_D$	$V_R = 0V$ $f = 1MHz$		5	pF
Reveres recovery time	$t_{rr}$	$I_F = I_R = 30mA, R_L = 100\Omega$		50	ns

# Typical Characteristics

**Forward Characteristics**

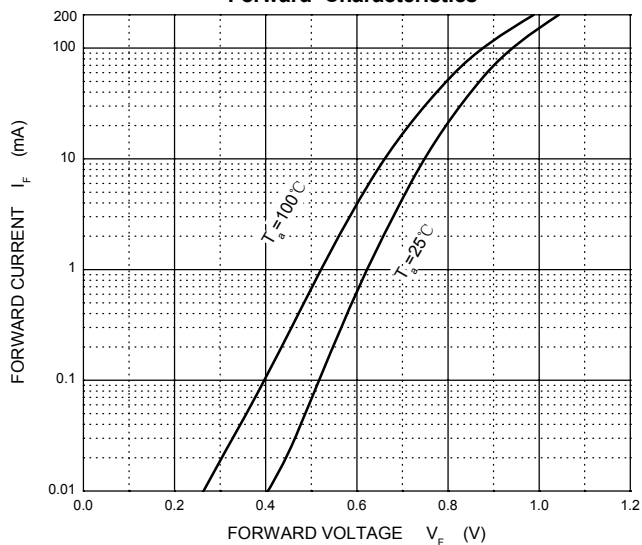

**Reverse Characteristics**

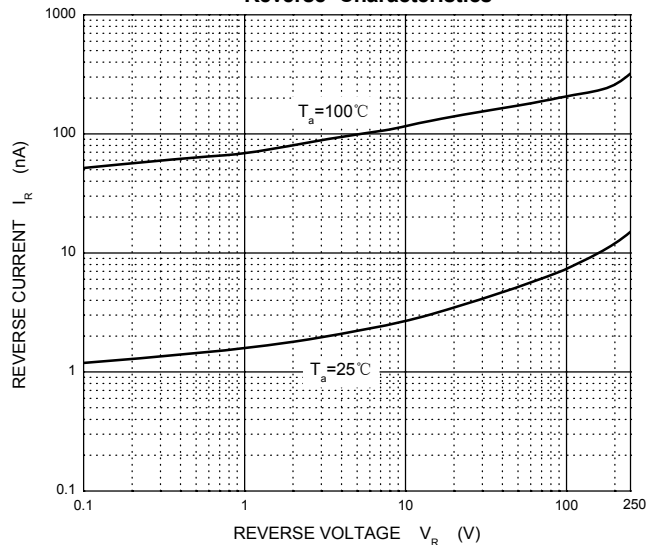

**Capacitance Characteristics Per Diode**

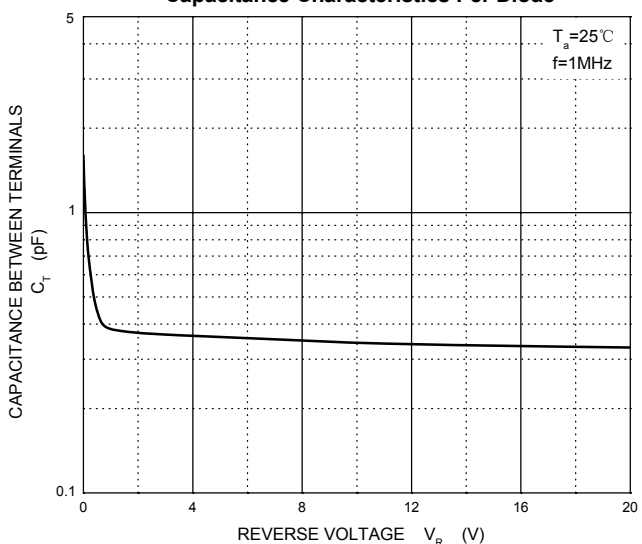

**Power Derating Curve**

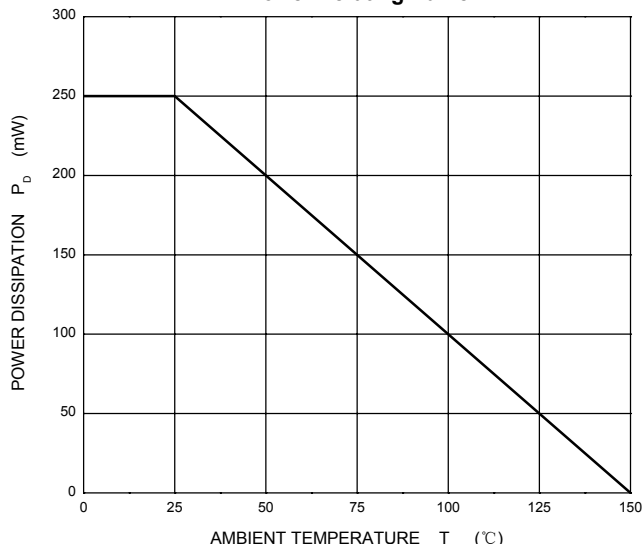

## SOT-23 Package Outline Dimensions

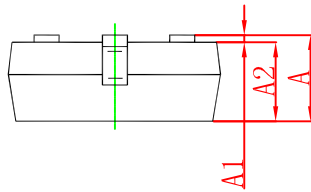
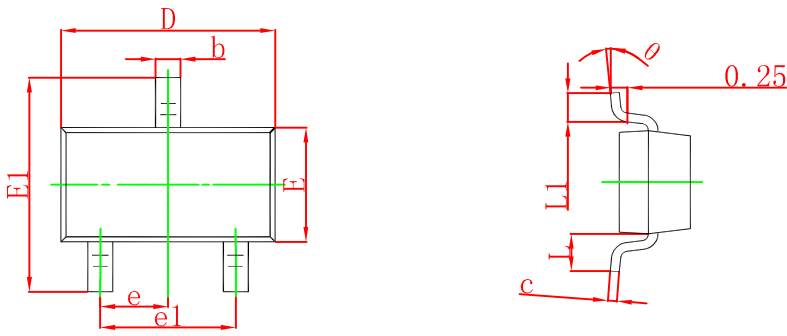

Symbol	Dimensions In Millimeters		Dimensions In Inches	
	Min	Max	Min	Max
A	0.900	1.150	0.035	0.045
A1	0.000	0.100	0.000	0.004
A2	0.900	1.050	0.035	0.041
b	0.300	0.500	0.012	0.020
c	0.080	0.150	0.003	0.006
D	2.800	3.000	0.110	0.118
E	1.200	1.400	0.047	0.055
E1	2.250	2.550	0.089	0.100
e	0.950 TYP		0.037 TYP	
e1	1.800	2.000	0.071	0.079
L	0.550 REF		0.022 REF	
L1	0.300	0.500	0.012	0.020
$\theta$	0°	8°	0°	8°

## SOT-23 Suggested Pad Layout



- Note:
1. Controlling dimension: in millimeters.
  2. General tolerance:  $\pm 0.05\text{mm}$ .
  3. The pad layout is for reference purposes only.

### NOTICE

JCET reserve the right to make modifications, enhancements, improvements, corrections or other changes without further notice to any product herein. JCET does not assume any liability arising out of the application or use of any product described herein.

# SOT-23 Tape and Reel

## SOT-23 Embossed Carrier Tape

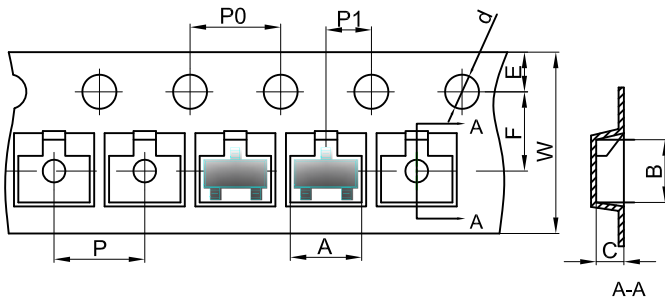

### Packaging Description:

SOT-23 parts are shipped in tape. The carrier tape is made from a dissipative (carbon filled) polycarbonate resin. The cover tape is a multilayer film (Heat Activated Adhesive in nature) primarily composed of polyester film, adhesive layer, sealant, and anti-static sprayed agent. These reeled parts in standard option are shipped with 3,000 units per 7" or 17.8cm diameter reel. The reels are clear in color and is made of polystyrene plastic (anti-static coated).

Dimensions are in millimeter

Pkg type	A	B	C	d	E	F	P0	P	P1	W
SOT-23	3.15	2.77	1.22	Ø1.50	1.75	3.50	4.00	4.00	2.00	8.00

## SOT-23 Tape Leader and Trailer

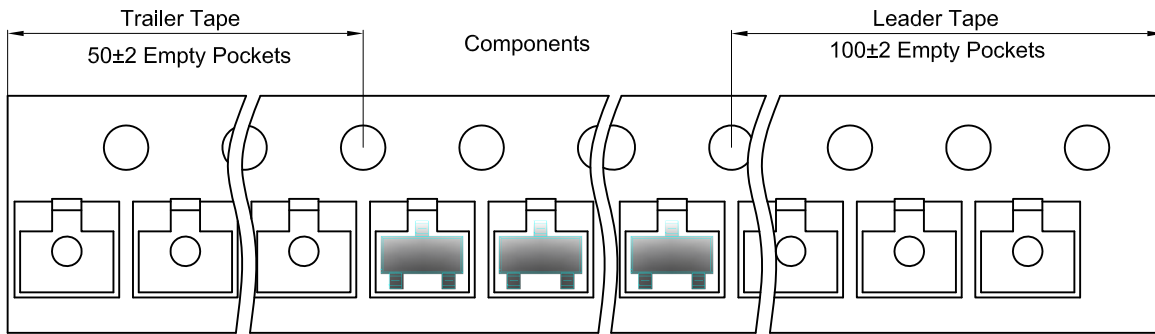

## SOT-23 Reel

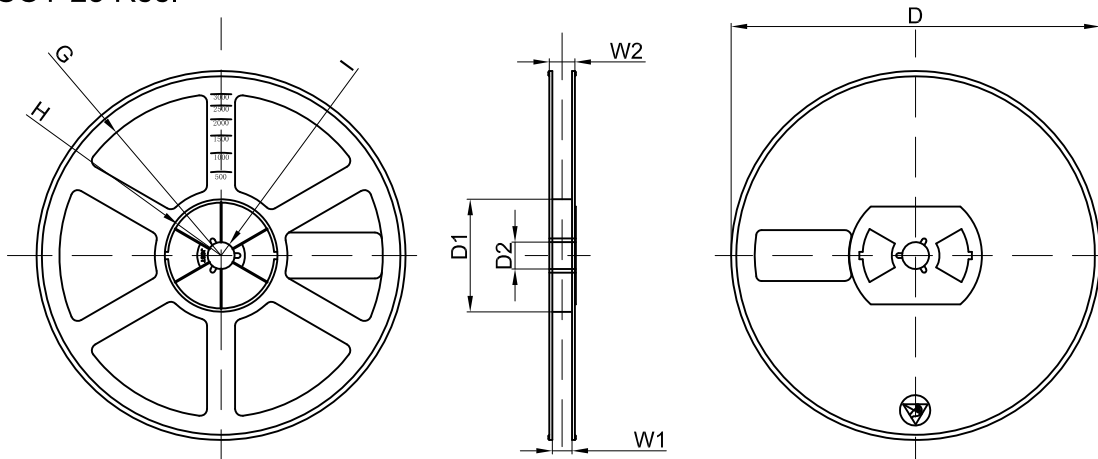

Dimensions are in millimeter

Reel Option	D	D1	D2	G	H	I	W1	W2
7"Dia	Ø178.00	54.40	13.00	R78.00	R25.60	R6.50	9.50	12.30

REEL	Reel Size	Box	Box Size(mm)	Carton	Carton Size(mm)	G.W.(kg)
3000 pcs	7 inch	45,000 pcs	203×203×195	180,000 pcs	438×438×220	